

Data sheet for dual control lifts with a full height door at the uppermost floor (max. travel 7m, 400kg)
 For dual control lifts with a 1/2 height gate at the uppermost floor see separate data sheet.

Ramp Option (4)

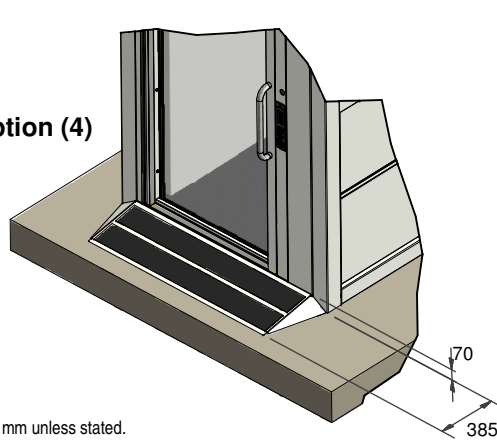

Notes:

- (1) All dimensions in mm unless stated.
- (2) 2500mm minimum floor to floor is required for entrances above each other on the same side.
- (3) Headroom is dependant upon the travel - please contact us for further information.
- (4) If pit cannot be formed a ramp is available as an optional extra.
- (5) Min. lintel height required for standard door closers = 2150mm. Min. lintel height for a powered fire door closer = 2250mm (add 70mm to either dim if ramp option is being used - this applies only to the lower floor).
- (6) Part M (England & Wales) and section 4.2 of the Technical Handbook (Scotland) compliant.
- (7) Aperture & Footprint dimensions will increase by 10mm on each side when a 60 minute fire door is specified.

Electrical Requirements:

- (8) Provide dedicated single phase supply protected by a 13amp type D MCB. The lift supply is to terminate in a lockable isolator at a position shown on builders work diagram.
- (9) Provide a 13amp electrical outlet socket adjacent to the lift installations at all levels. The supply to these sockets is not to be derived from the lift supply detailed in Note 7 above
- (10) Ensure that lighting at all landing levels is not less than 50lux.

Fixings:

- (11) The lift is fixed to the floor at the base of the enclosure. Fixings are also required at other points, the exact location depends on travel and configuration. Please contact us to discuss further.

Control Equipment:

- (12) The drive unit and electrical control equipment are housed in a separate enclosure, which should be wall mounted and located within 5m (hose run) away from the base of the lift (guide side).

Control Equipment

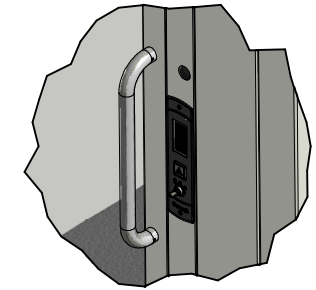
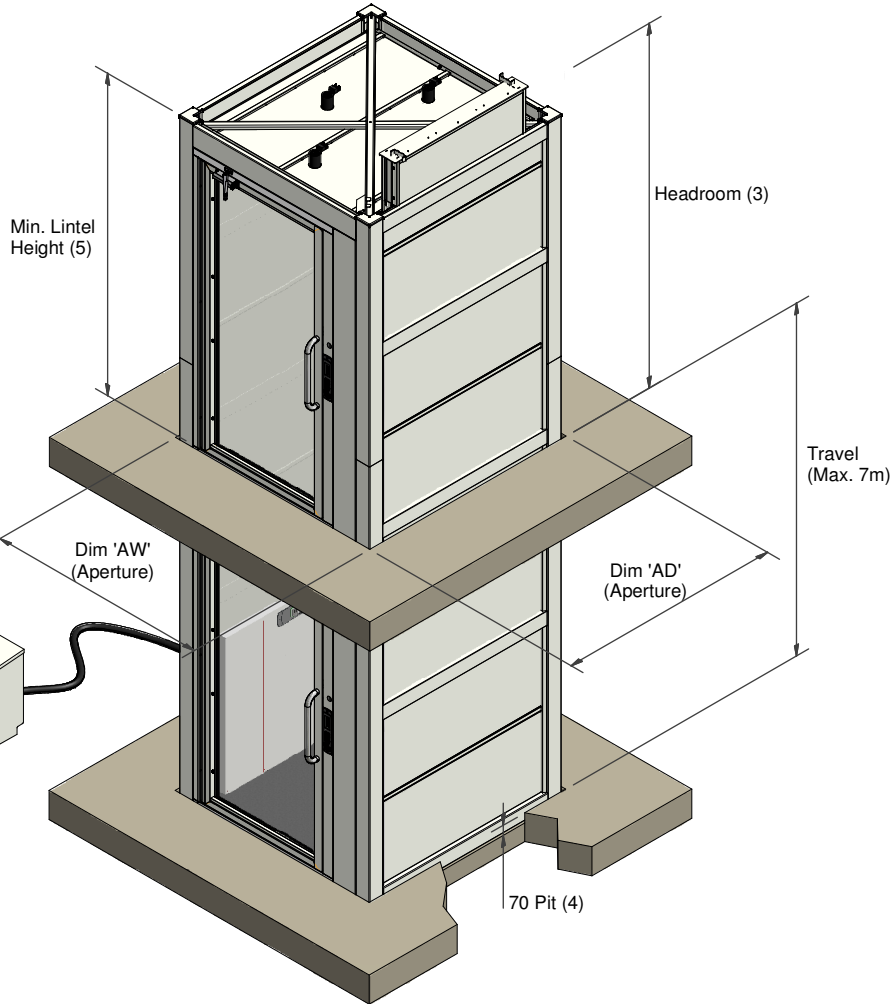
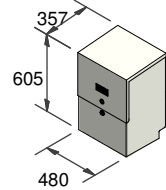

Call Station

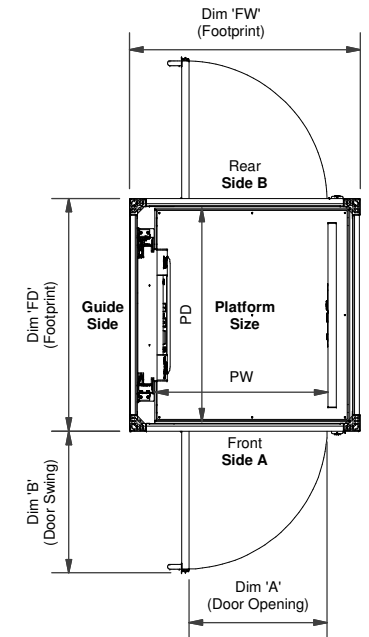

	Door opening	Door swing	Aperture (+10/-0) (7)		Footprint (7)	
Platform size (PW x PD)	Dim 'A'	Dim 'B'	Dim 'AW'	Dim 'AD'	Dim 'FW'	Dim 'FD'
1125 x 1400 (6)	900	1010	1540	1560	1510	1526

Waiver

The data sheet is for guidance only & must not be used for proper working drawings. Please contact us for particular details before proceeding. Owing to our policy of continual improvement, we reserve the right to alter specifications & dimensions without prior notice.